

# 6-Leg Stand

Large Width

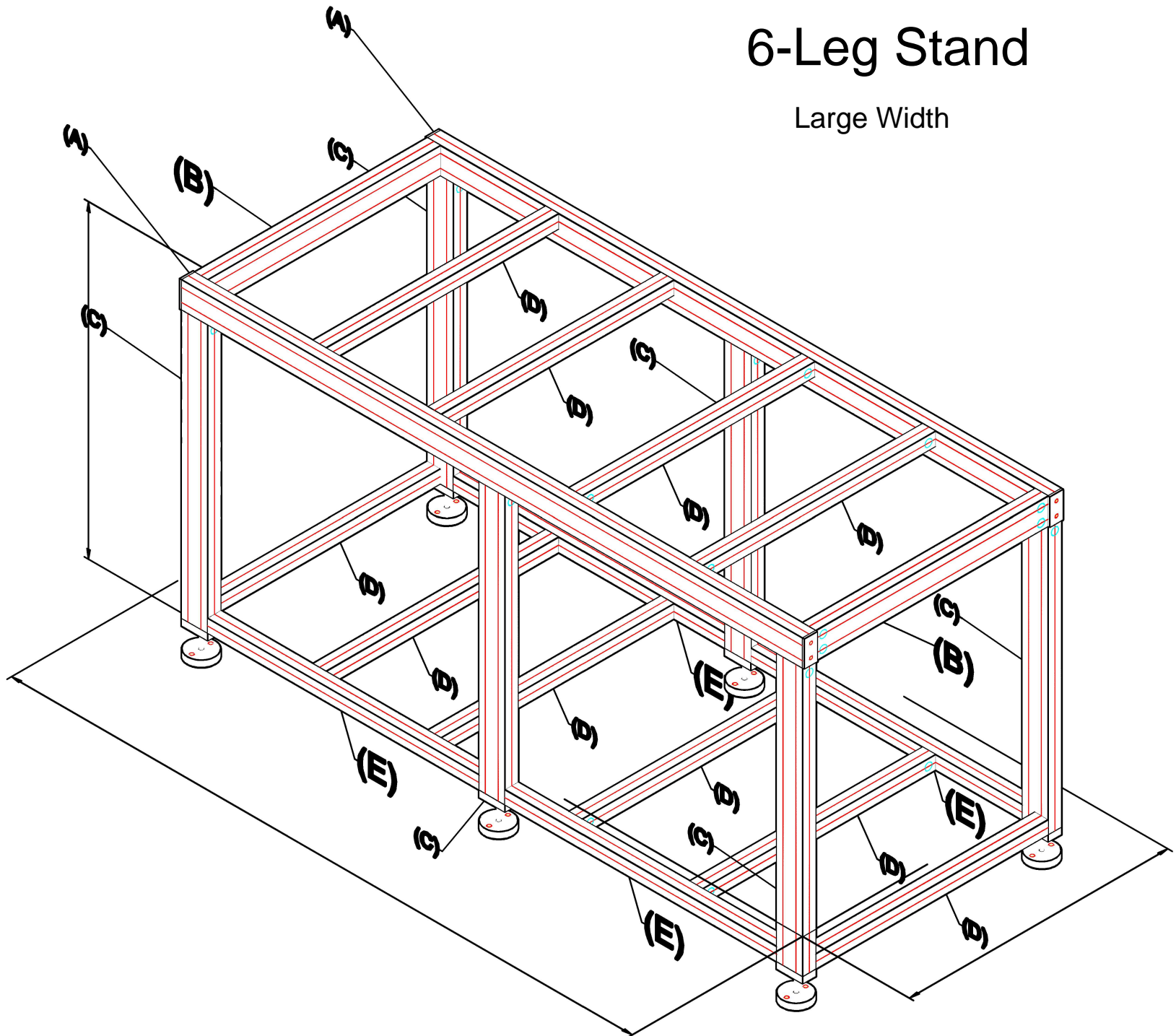

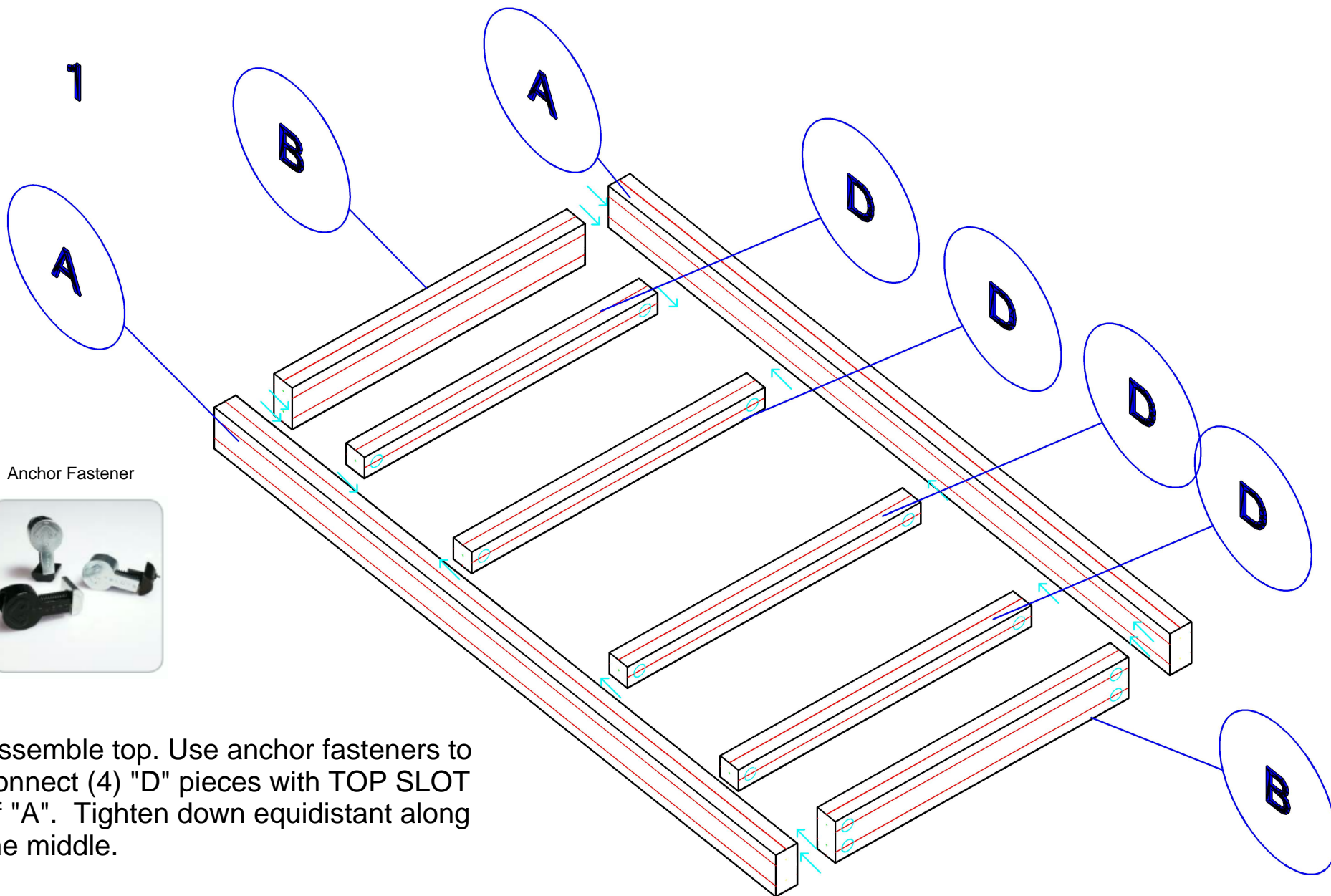

Anchor Fastener



Assemble top. Use anchor fasteners to connect (4) "D" pieces with TOP SLOT of "A". Tighten down equidistant along the middle.

Use anchor fasteners to connect a "B" on each end of "A", flush with end.

(Image spacing may not be to scale)

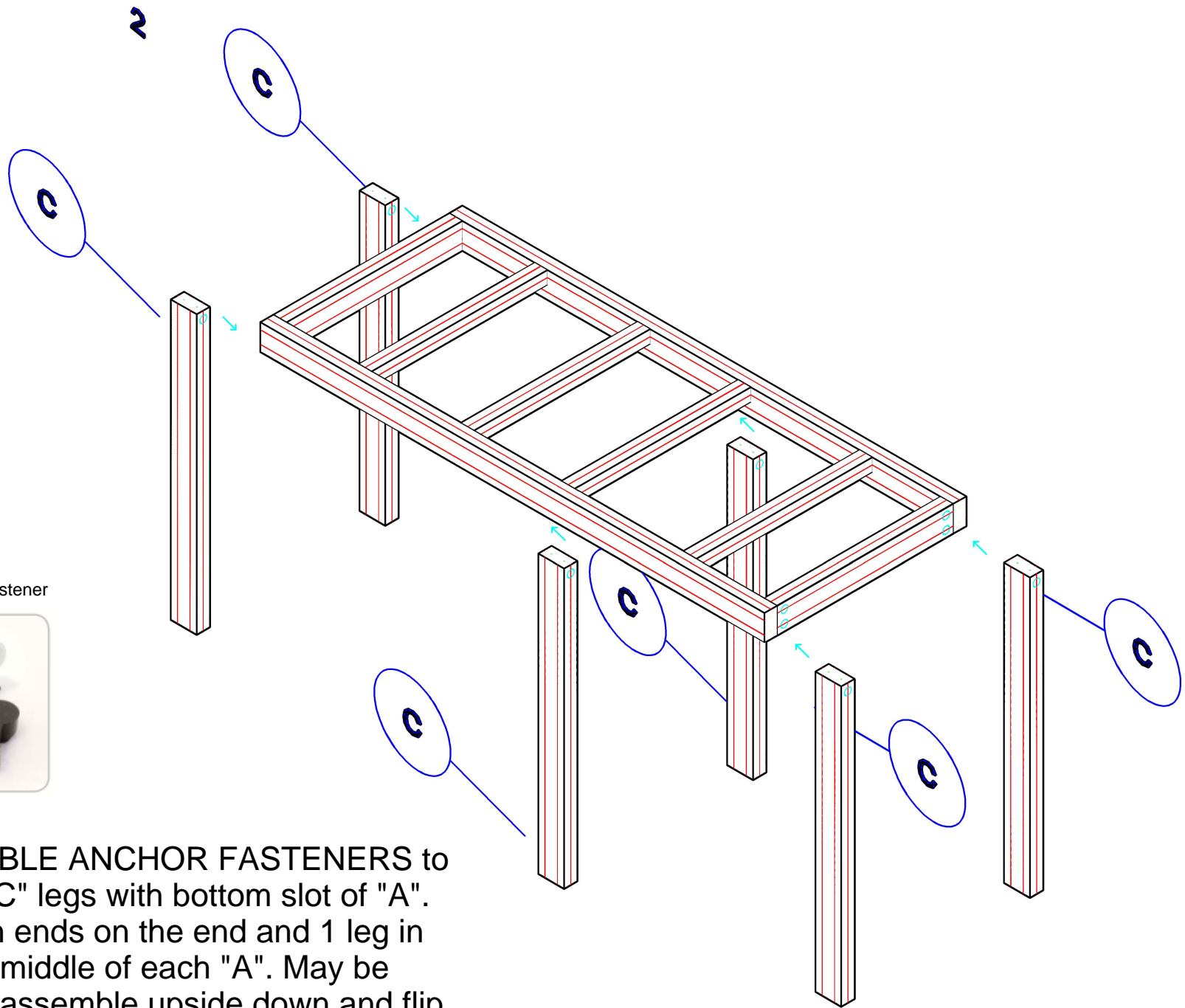

Double Anchor Fastener



Use **DOUBLE ANCHOR FASTENERS** to connect "C" legs with bottom slot of "A". Flush with ends on the end and 1 leg in the exact middle of each "A". May be helpful to assemble upside down and flip entire stand over when complete

Anchor Fastener



Use anchor fasteners to connect "D"s with SIDE SLOT of "E"s, forming base. Side slot refers to adjacent slot when anchor counterbore of E is facing up or down

Use (2) "D"s per (2) "E"s as shown, and tighten down "D" equidistant within "E"s

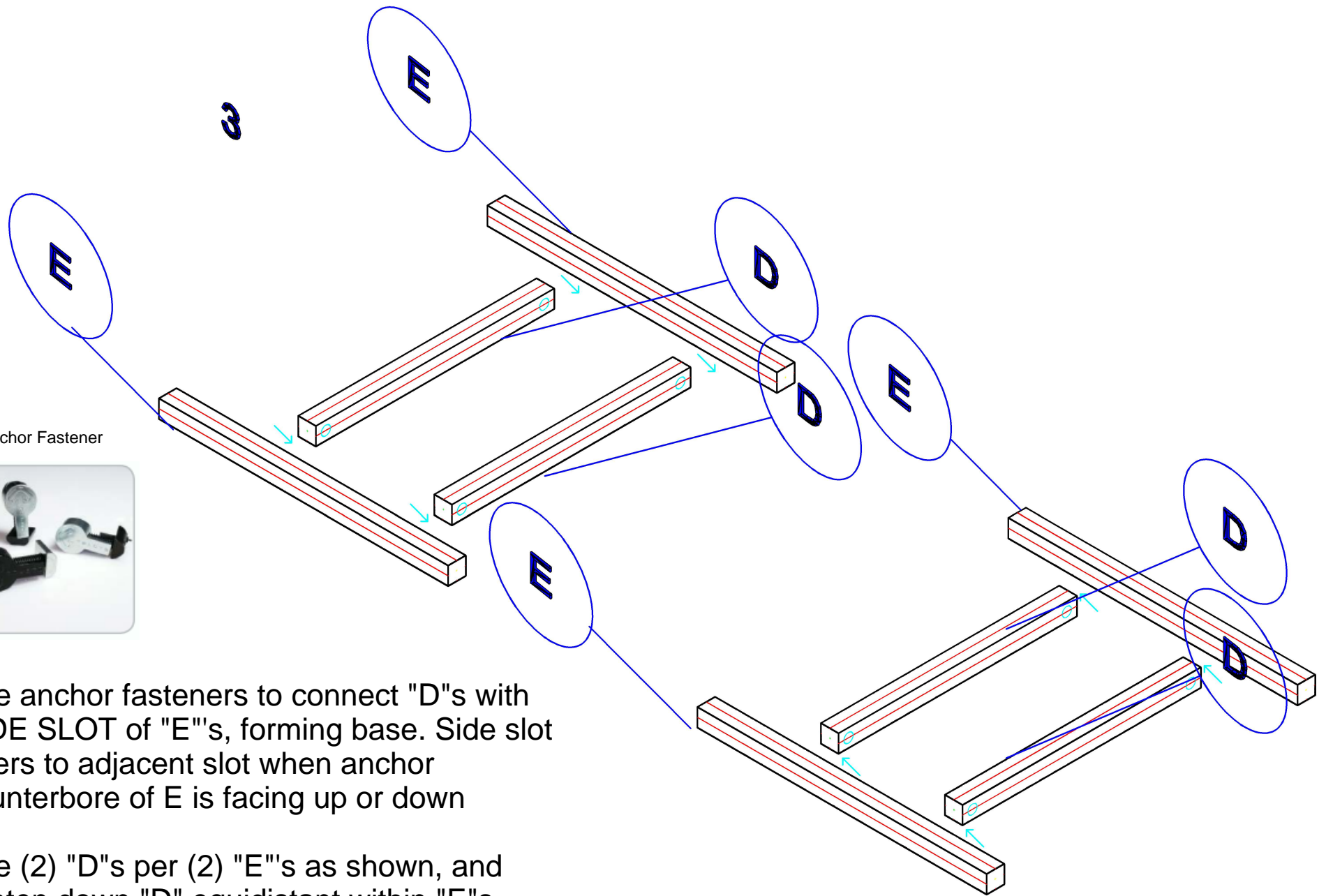

4

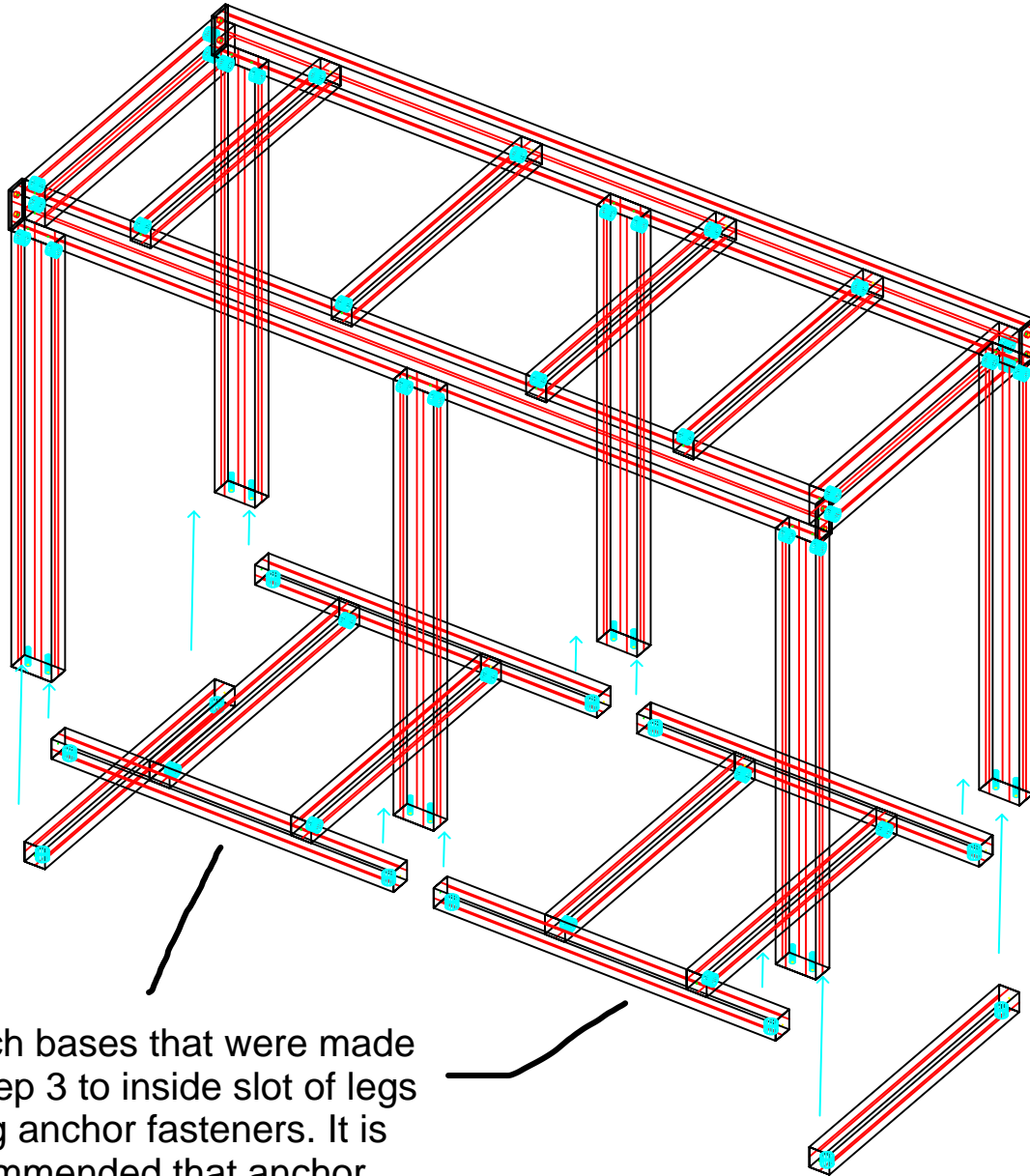

Attach bases that were made in Step 3 to inside slot of legs using anchor fasteners. It is recommended that anchor fasteners face down for full access of top slot.

Attach last of "D"s to outside slot of leg using anchor fastener. For middle "D" and leg it does not matter which slot is used. Face anchor fasteners down for full access of top slot.

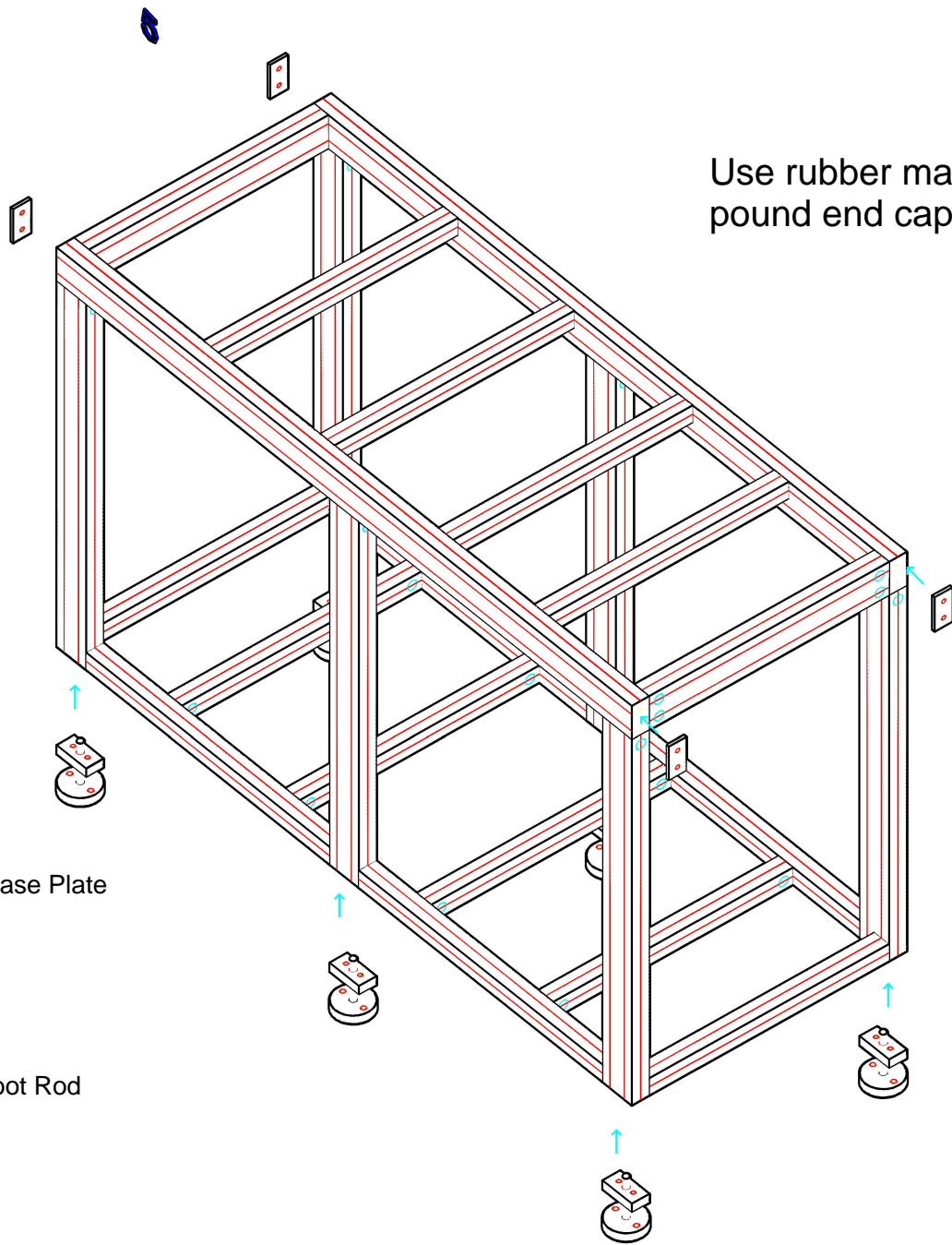

Use rubber mallet (or handle of T wrench) to gently pound end caps into exposed ends of stand top

Base Plate

Foot Rod

Foot Pad

-Finish by using bolts to thread outside holes of foot base plate into the holes at the bottom of the legs.

-Thread the rod of the foot into the center hole of the base plate  
-Using a rubber mallet or weight of the stand, snap the ball joint into the round indentation of the foot pad.

FOR CASTERS: Caster base plate and casters will connect to the legs in the same fashion